

MK ELECTRIC HEAT SERIES

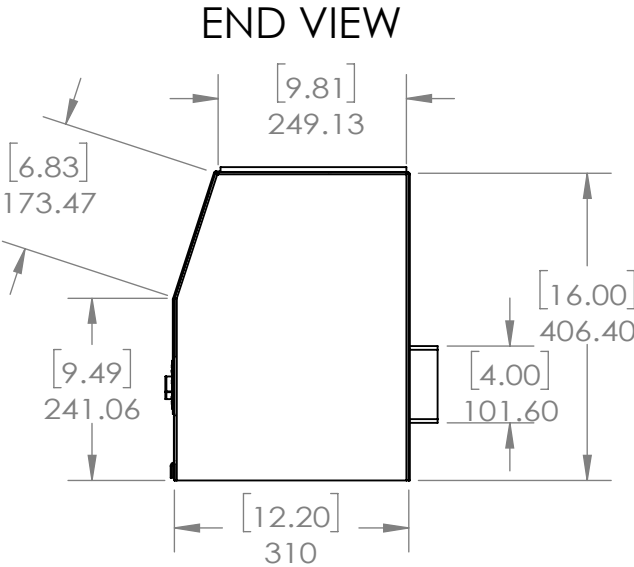
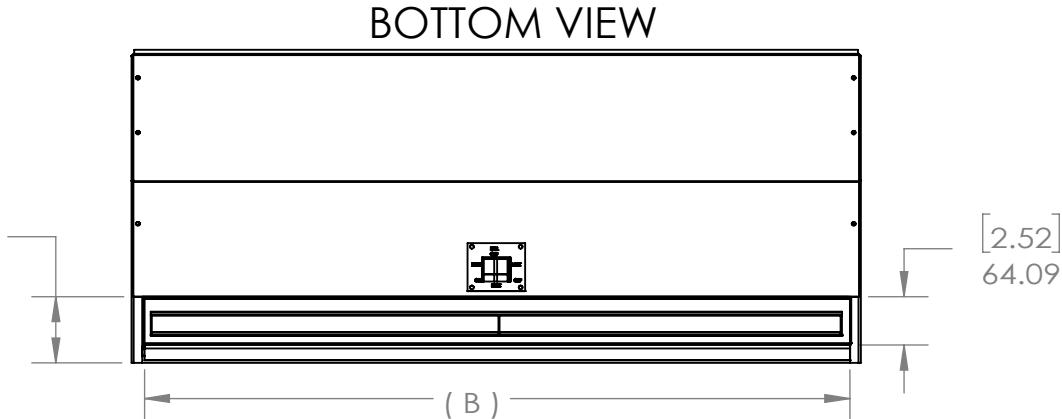
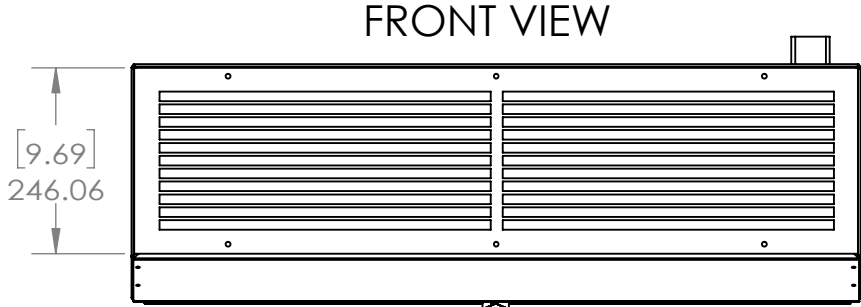
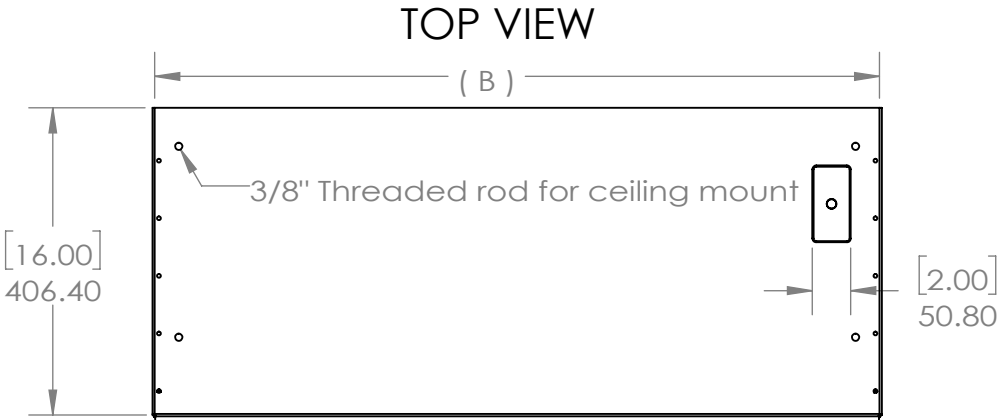
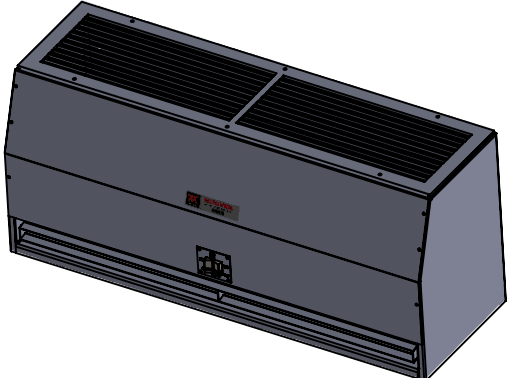

MODEL	NOZZLE WIDTH (A INCH / MM)	MOUNTING WIDTH (INCH / MM)	OVREALL WIDTH (B INCH / MM)
MK-1-36-E	36.75 / 933.45	36.75 / 933.45	37.75 / 958.85
MK-2-48-E	48.75 / 1238.25	48.75 / 1238.25	49.75 / 1263.65
MK-2-60-E	60.75 / 1543.05	60.75 / 1543.05	61.75 / 1568.45
MK-2-72-E	72.75 / 1847.85	72.75 / 1847.85	73.75 / 1873.25

MINIVEIL INDUSTRIES LTD		
Project		
Location		
Engineer		
DWG #	2019MK-E	MARK DUAL SPEED ELECTRIC HEAT
Date	2019/01/04	
By	JLL	